



# RALLY GUIDE

15-19.09.2020

SPONSORS



PARTNER OF



RESPECTED PARTNERS



## Table of contents

---

TABLE OF CONTENTS	2
WELCOME TO RALLYE BRESLAU POLAND 2020	3
CONTACT DETAILS	4
OFFICIAL LOGO OF THE EVENT	4
OFFICIAL LANGUAGE OF THE EVENT	4
ORGANISING COMMITTEE	5
PANEL OF STEWARDS	5
OFFICIALS OF THE RALLY	5
PROGRAM & CRITICAL DEADLINES	6
COVID-19 RELATED GUIDELINES AND ADDITIONAL MEASURES	7
PRELIMINARY ITINERARY	8
DISTANCE OVERVIEW	8
SAFETY INSTRUCTIONS	9
RALLY CONTROL CENTRE	10
CATEGORIES AND CLASSES	10
TECHNICAL SCRUTINEERING	11
RALLY SAFETY SYSTEM/COM-BOX	11
RALLY SAFETY SYSTEM – REQUIREMENTS AND MOUNTING	12
RENTAL OF RALLY SAFETY SYSTEM	15
COORDINATES FORMAT	15
PHOTO SERVICE AND PHOTO PACKAGES	16
ADMINISTRATIVE CHECK – REQUIRED DOCUMENTS	17
CAMPS	18
CAMP FACILITIES	18
CAMP MAPS	19
CAMP ACCESS	20
SMS SERVICE AND ACCESS PASS:	21
ELECTRICITY	22
WARNINGS	22
WILDLIFE ON THE RALLY ROUTE	22
CATERING	23
CAR WASH AND FUEL STATIONS	23
WASTE	23
OIL/LIQUIDS	23
GENERAL ENVIRONMENTAL REGULATIONS	24
REFUELLING	24
ADVERTISING AND IDENTIFICATION. STICKER PLAN.	25
IDENTIFICATION	26
RALLY SIGNS	27
MANUAL START HANDLING	29
INSTRUCTIONS FOR SAFETY	30
USEFUL INFORMATION	31

## Welcome to Rallye Breslau Poland 2020

---

Dear Participants,

It is my pleasure and honour to welcome you to Rallye Breslau Poland 2020. In this turbulent year we are happy to have the opportunity to organise our 5-day event and judging from the entry list I think you will be happy as well.



The all-time record for the Rallye Breslau Poland is 350 Competitors and at the moment we are slowly approaching this number. It is a magnificent start list this year. During the day and in the evening the Breslau will shine with all the teams who have chosen to join us. Thank you for your trust!

In the Rallye Breslau Poland every stage, every corner is exciting. The variation in the landscapes and the tracks is great. You have to be able to do everything: high speed racing, proper navigation and teamwork.

To ensure your rally pleasure we split between bikes, quads and SSV, cars and trucks in Cross Country class. This means fewer competitors on the track, faster starts and a safer race for all of us. The battle in the Extreme Category will be for the cars and the trucks.

It will be a pleasure for all to load the vehicles, come to Poland and see each other again. But remember to stay safe. In these challenging times we need to keep our distance and follow the procedures for hygiene as outlined in this Rally Guide and the Covid-19 Guidelines.

The Polish Authorities, Forestry, Regions, Municipalities and Land Owners welcome us. Everyone looks forward to Rallye Breslau Poland 2020, and we are most welcome in this beautiful region of Poland.

On behalf of the entire organisation crew,  
See you soon in Poland!

Alexander Kovatchev  
Director of RBI Sport

## Contact details

---

### PERMANENT SECRETARIAT:

RBI Sport Ltd.  
75, Sankt Peterburg Blvd.  
4006 Plovdiv  
Bulgaria

Tel.: +359 32 277 993  
Fax: +359 32 277 990  
E-mail: [info@rallye-breslau.com](mailto:info@rallye-breslau.com)  
Website: <https://rallye-breslau.com/>

### RALLY OFFICE:

It will be placed in the camps and will be clearly marked.  
Opening and closing work hours will be published on the Electronic Notice Board.

### OFFICIAL NOTICE BOARD:

There will be no physical Official Notice Board at the rally to avoid gathering of people at close distance.

### ELECTORNIC NOTICE BOARD:

Digital Notice Board will be available online. The exact URL address will be communicated. All results, classifications, communication, bulletins and other important documents will be published there.

### MEDIA CONTACT DETAILS:

RBI Media Crew: [info@rallye-breslau.com](mailto:info@rallye-breslau.com)

## Official logo of the event

---



## Official language of the event

---

The official language of the event is English

According to the participants' origin we aim to ensure also communication in German, French, Polish, Dutch, and Bulgarian.

## Organising Committee

---

### Chairman:

Alexander Kovatchev – President of RBI Sport Ltd.

### Members:

Wojciech Legutko – Secretary General RBI Sport

Vilena Kovatcheva – Marketing manager

Daniela Rousekova – Rally administration manager

Konstantin Panayotov – Route manager

Kamil Jablonski – Rally Control Manager

Achim Lust – Safety & Recovery

Zbyszko Gaik – Manager Operation in Poland

Niels Hatzmann - Media

## Panel of Stewards

---

### Chairman:

Andreas Pflug

### Members:

TBA

TBA

## Officials of the Rally

---

Clerk of the Course	Alexander Kovatchev
Assistant Clerk of the Course	Wojciech Legutko
Chief Marshal	Bernd Habermeier
Deputy Coc – Sport	Konstantin Panayotov
Deputy CoC – Safety & Recovery	Achim Lust
Deputy CoC – Organisation	Dimitar Lazarov
Deputy CoC – Media Press Officer	Niels Hatzmann
Route Manager	Konstantin Panayotov, Zbyszko Gaik
Secretary of the Event	Daniela Rousekova, Vilena Kovatcheva
Rally Control Manager	Kamil Jablonski
Chief Scrutineer	Jürgen Teichert
Competitor Relations Officer	Michal Ginter
Chief Timekeeper	Ivan Marinov
Chief Medical Officer	Dr. Artur Gawlowski
Service Park Manager	Denis Koch
Environmental Officer	Zbyszko Gaik

## Program & Critical Deadlines

Opening date for entries: 19.12.2019

Closing date for online entries: 24.08.2020

Opening Camp 1: 12.09.2020 from 15:00 hrs.

Start of the administrative check: 12.09.2020 from 16:00 hrs.

Start of the technical scrutineering: 13.09.2020 from 09:00 hrs.

<b>19.12.2019   Thursday</b>	
00:00	Start of Online Registration
<b>24.08.2020   Monday</b>	
23:59	Closing of Online Registration
<b>12.09.2020   Saturday</b>	
from 15:00	Camp 1 – Opening
16:00 – 19:00	Administrative check - wear face mask, s. Covid-19 Guidelines
<b>13.09.2020   Sunday</b>	
09:00 – 20:00*	Administrative check - wear face mask, s. Covid-19 Guidelines
09:00 – 20:00*	Technical check - wear face mask, s. Covid-19 Guidelines
09:00 – 20:00*	GPS Tracking system installation - wear face mask, s. Covid-19 Guidelines
<i>*Breaks 10:30 – 11:00 , 12:30 - 13:30 and 16:00 – 16:30</i>	
<b>14.09.2020   Monday</b>	
08:00 - 15:00	Administrative check - wear face mask, s. Covid-19 Guidelines
<i>Breaks 10:00-10:30, 12:00 - 13:00</i>	Technical check - wear face mask, s. Covid-19 Guidelines
	GPS tracking installation - wear face mask, s. Covid-19 Guidelines
19:00	Roadbook collection for Leg 1 wear face mask, s. Covid-19 Guidelines
21:00	Driver's briefing <b>[MANDATORY]</b> wear face mask, s. Covid-19 Guidelines
22:00	Publication of Start list for Leg 1
<b>15.09.2020   Tuesday</b>	
08:00	Start of LEG 1
19:00	LEG 1 - Provisional classification
21:00	Driver's briefing <b>[MANDATORY]</b> wear face mask, s. Covid-19 Guidelines
<b>16.09.2020   Wednesday</b>	
08:00	Start of LEG 2
19:00	LEG 2 - Provisional classification
21:00	Driver's briefing <b>[MANDATORY]</b> wear face mask, s. Covid-19 Guidelines
<b>17.09.2020   Thursday</b>	

08:00	Start of LEG 3
13:00	Camp 2 - Opening
22:30	Start of NIGHT STAGE
<b>18.09.2020   Friday</b>	
07:30	LEG 3 – Provisional classification
08:00	Driver's briefing <b>[MANDATORY]</b> wear face mask, s. Covid-19 Guidelines
09:00	Start of LEG 4
20:00	LEG 4 – Provisional classification
21:00	Driver's briefing <b>[MANDATORY]</b> wear face mask, s. Covid-19 Guidelines
<b>19.09.2020   Saturday</b>	
08:00	Start of LEG 5
16:30	LEG 5 – Provisional classification
	Podium and award giving directly after the finish of the last rally leg
<b>20.09.2020   Sunday</b>	
12:00	Camp 2 - Closing

\* All information can be changed without notice. For information purpose only!

## ***COVID-19 Related guidelines and additional measures***

Everyone is familiar with the current pandemic issues and RBI Sport as rally organizer will have to apply specific measures to minimize the risk of the Covid-19 spread as well.

**You can find the COVID-19 Related guidelines and additional measures on the following link:**

Click here>>><https://rallye-breslau.com/communications/>

**Please read and prepare for specific Covid-19 related guidelines and additional measures.**

## Preliminary Itinerary

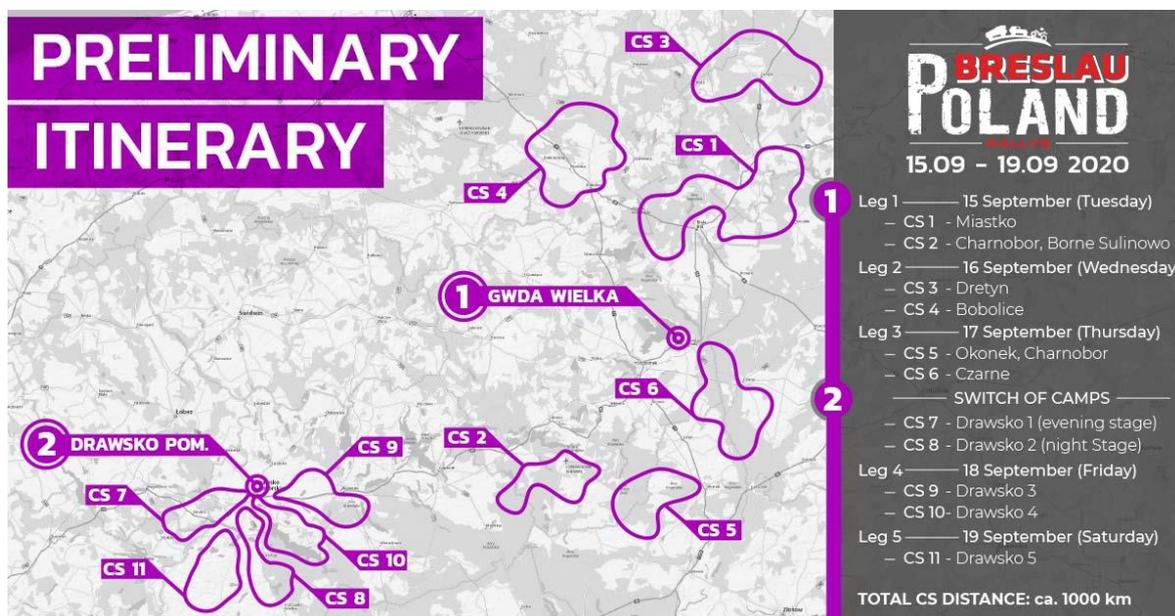

## Distance overview

PRELIMINARY ITINERARY - CROSS COUNTRY CATEGORY				
	CS dist.	Liaison dist.	Conect dist.	Total dist.
15.09.2020 (Tuesday)	180,00	70,00	0,00	250,00
16.09.2020 (Wednesday)	210,00	30,00	30,00	270,00
17.09.2020 (Thursday)	210,00	115,00	55,00	380,00
18.09.2020 (Friday)	200,00	20,00	115,00	335,00
19.09.2020 (Saturday)	200,00	10,00	10,00	220,00
<b>TOTALS</b>	<b>1000,00</b>	<b>245,00</b>	<b>210,00</b>	<b>1455,00</b>

PRELIMINARY ITINERARY - EXTREME CATEGORY				
	CS dist.	Liaison dist.	Conect dist.	Total dist.
15.09.2020 (Tuesday)	115,00	70,00	0,00	185,00
16.09.2020 (Wednesday)	200,00	30,00	30,00	260,00
17.09.2020 (Thursday)	180,00	110,00	55,00	345,00
18.09.2020 (Friday)	180,00	20,00	115,00	315,00
19.09.2020 (Saturday)	175,00	10,00	10,00	195,00
<b>TOTALS</b>	<b>850,00</b>	<b>240,00</b>	<b>210,00</b>	<b>1300,00</b>

## Safety Instructions

---

### **HIGHLY IMPORTANT:**

Offroad rallies in Poland are generally taking place on military polygons. These are strictly controlled military zones with special rules for usage and behaviour.



The military polygons CSWL Drawsko Pomorskie and Biedrusko are hospitable and highly respected partners with relations to Rallye Breslau lasting since more than 20 years. Rallye Breslau fully complies with the house order and the requirements of the military polygon and will **NOT tolerate** any infringement against the established rules.

### **WARNING:**

1. Racing vehicles are NOT allowed to drive on the polygon except during the rally legs.
2. Press vehicles are NOT allowed to drive on the polygon except being a part of the official press convoy of the rally.
3. Service vehicles are NOT allowed to drive on the polygon except using the assigned routes to the spectators' points given by the Organiser and ONLY till the Special Stage is still open.
4. Fans and other members of the racing teams are fully obliged to follow the orders of the Organiser.

**ANY INFRINGEMENT WILL BE PURSUED AND PENALISED!**

**Each person entering the polygon must have an identity document.**

For safety reasons it is forbidden to move away from the designated spectators' points.

For safety reasons it is forbidden to collect and lift objects that are on the ground.

While at spectators' points fans must pay special attention to any objects on the ground, as they may pose a danger.

**FOLLOW THE INSTRUCTIONS IN THE MILITARY POLYGON!**

## Rally Control Centre

Every team will receive stickers with the phones of Rally Control Centre. Please put the sticker on a place where you can always view the numbers in emergency situations during the rally.

**RALLY CONTROL**

**+359 879 400 911**

**+359 879 800 911**

## Categories and classes



CROSS COUNTRY	EXTREME	DISCOVERY
ENDURO ATV SSV CAR Limited Open TRUCKS <7.5t TRUCKS >7.5t	CAR Limited Open TRUCKS <7.5t TRUCKS >7.5t	ATV SSV CAR

**There is no ranking for category Discovery**

For Cross Country and Extreme - Minimum 7 vehicles should be registered in one class in order to make a separate ranking.

THERE WILL BE NO TEAM RANKING OR OVERALL CLASSIFICATION BY GROUPS.

## *Technical scrutineering*

---

The fact to present a vehicle at the technical check is considered as an implicit declaration of conformity.

Having stickered their vehicles according to the received sticker plan and after passing the administrative check the participants go to scrutineering.

**At the scrutineering will be controlled the obligatory technical condition and the mandatory equipment.**

**The vehicle must be presented at the scrutineering in the same way as it would go to the prestart.**

The participant receives the start permission after successfully passing technical scrutineering and administrative check.

The mandatory equipment for the particular category, such as first aid kit, towing straps, winching and recovery accessories must be prepared in advance in order to speed up the process of scrutineering. If needed, the ORGA will mark the presented equipment. All the requirements can be founded on the website

## *Rally Safety System/Com-Box*

---

Each rally vehicle will be fitted with a tracking device: "Rally Safety System".

By means of sensors the device communicates with satellites, locates the vehicle and makes each second a record of the exact position, the time, the speed and the driving direction plus many other parameters.

Everybody who has access to internet – no matter through PC, tablet or cell phone can follow the rally LIVE. An extra button will appear on the website [www.rallye-breslau.com](http://www.rallye-breslau.com) before the rally starts.

Through our unique feature called Rally Replay the event can be reviewed from many perspectives by competitors, fans, sponsors, authorities. Direct comparison between drivers can be done by just a mouse click. The entertainment and analysis last much longer.

**IMPORTANT:** This year the Geotraq Rally Safety System has been upgraded. The participants will drive with the latest feature – the Com-Box, allowing vehicle-to-vehicle communication. Modern technology enables the participants to request overtaking with a single push of a button. The subject of safety plays a key role and we are doing our best to incorporate meaningful improvements in the safety system.

Com-Box - HOW IT WORKS:

Click here to watch the video>>> [Com-Box How It Works](#)



Geotraq Com Box How it works

## *Rally Safety System – requirements and mounting*

In order to prepare your rally vehicle for the additional “Com-Box” unit read the installation manual: “Appendix 5 – Rally Safety System”.

Click here >>> [Appendix 5 - Rally Safety System](#)

**IMPORTANT!!!**  
**Appendix 5 – Rally Safety System**

Briefly: prepare and check the power supply for the tracking system and get ready for the installation of the “Com-Box” unit.

The required mounting bracket for the “Com-Box” unit will be delivered to all drivers at the administrative check in order for your mechanics to install it on the rally vehicle before you go to scrutineering.

## POWER SUPPLY

1. The battery master cut-off (kill) switch **MUST NOT DISCONNECT** the power supply for the tracking system.
2. It is the responsibility of the competitors alone to provide, **DIRECT POWER SUPPLY** from the vehicle’s battery according to the drawings
3. The power cables must be “flexible” (multi wire), insulated cables – 2 x 1.5mm<sup>2</sup> – RED and BLACK coloured.
4. The connection is recommended to have an **IN-LINE FUSE** - “BLADE TYPE” of 5A.
5. The wires must be prepared in advance and connected to the vehicle’s battery when the vehicle is presented for scrutineering.
6. The cable must have minimum 50cm extra usable length from the middle of the dash board (See installation position).
7. The connection to the Rally Safety System will be done with simple connector terminals supplied by the organizer.

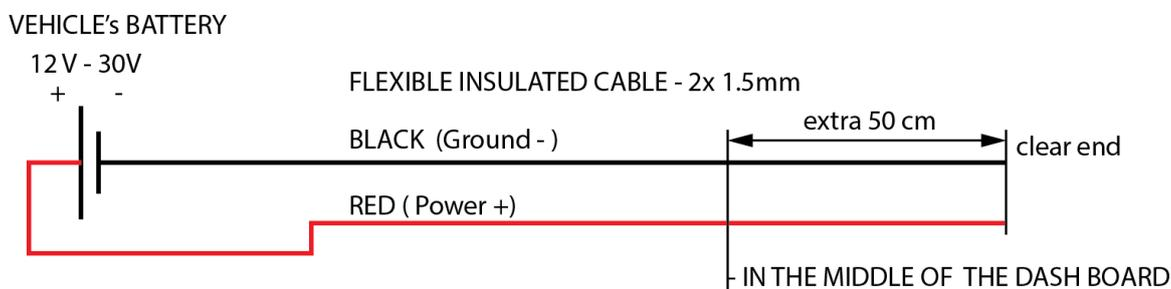

## CONNECTORS:

The power supply cables (Power+ and Ground-) must be equipped with **FULLY INSULATED FEMALE Crimp Spade Terminal Connector** - 6.3 x 0.8mm.



## COM-BOX INSTALLATION. PREPARE FOR THE INSTALLATION OF THE BRACKET:

1. Base/Mount bracket will be distributed at the administrative check to each crew and must be installed on the rally vehicle before scrutineering.
2. Base/Mount bracket can be directly bolted or zip-tied or stuck to the rally vehicle at the designated location by the crew. It is the responsibility of the crew alone to install the bracket before scrutineering.
3. A minimum of 75mm on the sliding side of the bracket and 25mm on the antenna side must be free for the Com-Box unit.
4. The installation location must be in reach of the Rider or Co-driver for operation in the rally.

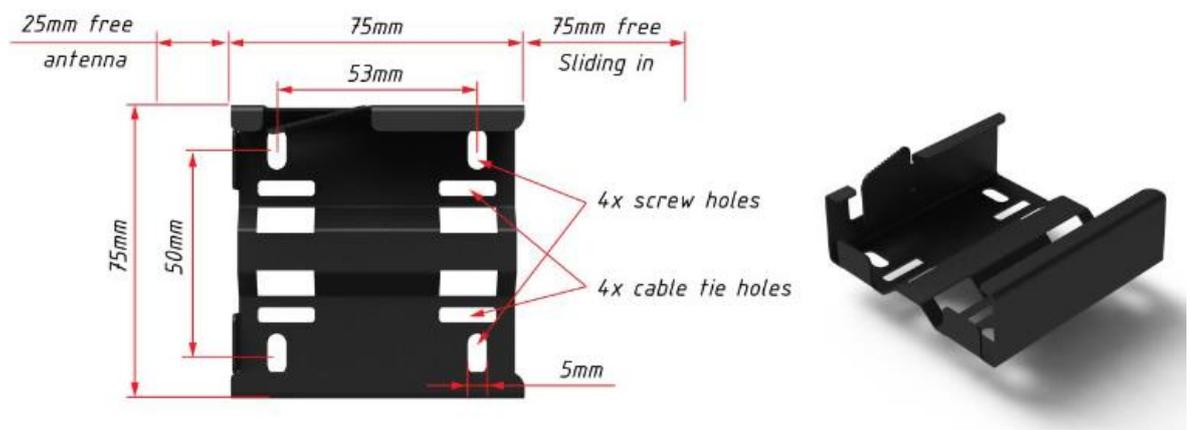

6.5. No bolt/screw heads or cable/zip ties can protrude over the red line as marked below.

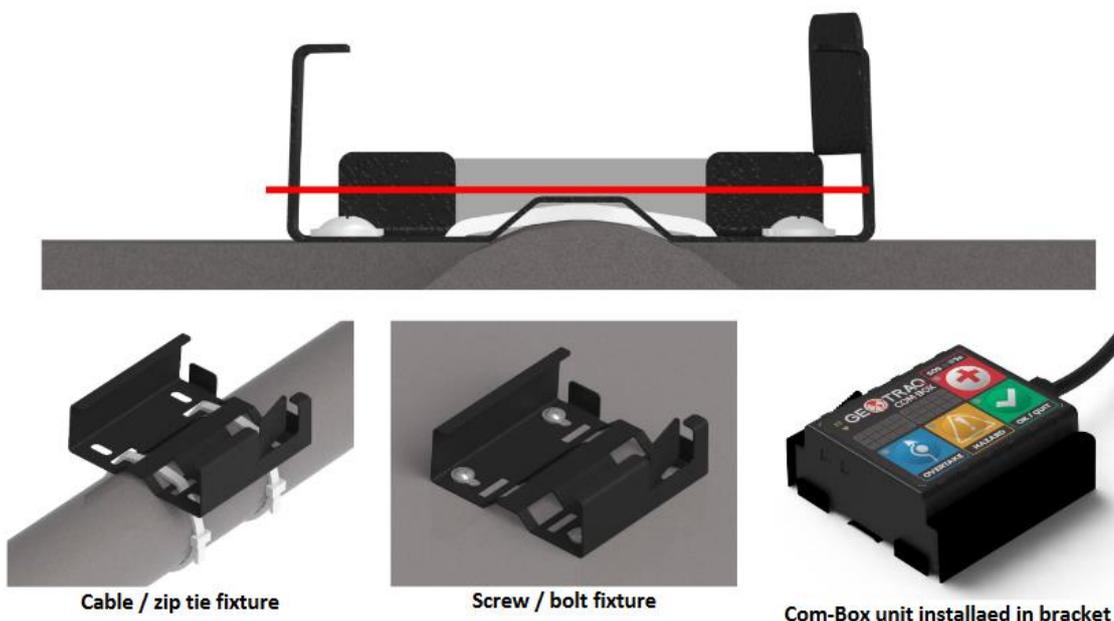

It is the responsibility of the competitors alone to provide enough space for the Com-Box.

It is mandatory that each rally vehicle has properly installed and working “RALLY SAFETY SYSTEM” on board.

### *Rental of Rally Safety System*

The system will be rented at the administrative check. The rental for the system is included in the entry fee.

At the administrative check has to be paid the deposit for the device: **200 euros** in cash. The deposit will be given back in the Rally Office after the rally finish or if the participant is out of race, as soon as he/she returns the devices undamaged.

### *Coordinates format*

World Geodetic System: WGS84  
Coordinates format: hddd.ddddd  
North: True North

## Photo service and photo packages

RBI Media Crew is a cooperation of the best off-road photographers, journalist and video makers - carefully selected and ready to face the action. You as a rally-participant, your team and your sponsors will profit with getting the best images, video feeds and stories for you and your followers. You race - the RBI Media Crew will cover you.

You can order your photo package during the administrative check.



**€ 199.90**

### PHOTO PACKAGE

Up to 100 photos overall

High resolution, best selection

One special artwork production\*

Personal use license

**BONUS:** Mobile wallpaper and layout for Breslau calendar\*\*



**€ 249.90**

### PHOTO PACKAGE + ONE PIC DAILY SERVICE

Up to 100 photos overall

One photo per race-day, send via email

High resolution, best selection

One special artwork production\*

Personal use license

**BONUS:** Mobile wallpaper and layout for Breslau calendar\*\*

All photos (full packages) will be delivered via online-transfer (max. 35 working days after the event), daily services every day via email.

\* On request selected by you from one of delivered photos

\*\* With up to 3 possibilities for personalisation by you own

## **Administrative check – required documents**

---

Every single person in the Camp (driver, co-driver, mechanic or assistance person, guest, press, ORGA member etc.) will have to come to the Administrative Check and sign the documents personally.

### **YOU HAVE TO PRESENT THESE DOCUMENTS IN ORIGINAL:**

#### **DRIVER, CO-DRIVER(s), RALLY VEHICLE**

1. Passport or identity card (original)
2. Driving license (original)
3. Vehicle registration (original)
4. Insurance card (green card) in original

#### **SERVICE PERSON AND VEHICLES**

1. Passport or identity card (original)
2. Vehicle registration (original)

### **IF YOU DIDN'T UPLOAD THE DOCUMENTS INTO THE ONLINE DATABASE YOU HAVE TO BRING COPIES OF ALL OF THEM.**

*Documents and personal data are treated by Rallye Breslau Int. Assn. strictly confidential.*

### **WHO IS CONSIDERED AS AN “ASSISTANCE PERSON OR A SERVICE PERSON”?**

The assistance/service person at Rallye Breslau is every person, which accompanies the racing team - mechanic, wife, husband, friend, fan of the racing team etc. These persons receive the full package of services at the rally and access to all rally facilities.

**IMPORTANT:** Rest payments of the fees can be done at the Administrative Check only in cash.

## Camps

### CAMP 1

#### GWDA WIELKA

**N53 45.019 E16 47.421**  
28.06.2019 – 02.07.2019

*Camp 1 – Opening*  
12.09.2020 at 15:00 hrs

*Move from Camp 1 to Camp 2:*  
Thursday, 17.09.2020

### CAMP 2

#### DRAWSKO POMORSKIE

**N53 30.907 E15 47.103**  
02.07.2019 – 06.07.2019

*Camp 2 – Opening*  
17.09.2020 at 13:00 hrs

*Camp 2 – Closing*  
20.09.2020 at 12:00 hrs

Special finish procedure and award giving directly after the finish of the last rally leg will take place. Special awards for the finishers and photo corner will be organized at the finish. RBI Sport is not allowed to organize the typical big Breslau party in the Camp because of the Covid-19 restrictions and the guidelines to avoid any form of people overcrowding at one place.

## Camp Facilities

The Organiser will provide the following services and **facilities** in the camps:

- Toilets
- Showers
- Water in limited quantities (not for drinking)
- Waste removal
- Catering

In each camp there will be the following **zones**:

- Area for crews and service
- Area for the ORGA
- Rally HQ
- Official Notice Board
- Medical zone
- Rally Control Centre
- Check out and GPS control
- FAN Shop
- Catering zone
- Press area

## Camp maps



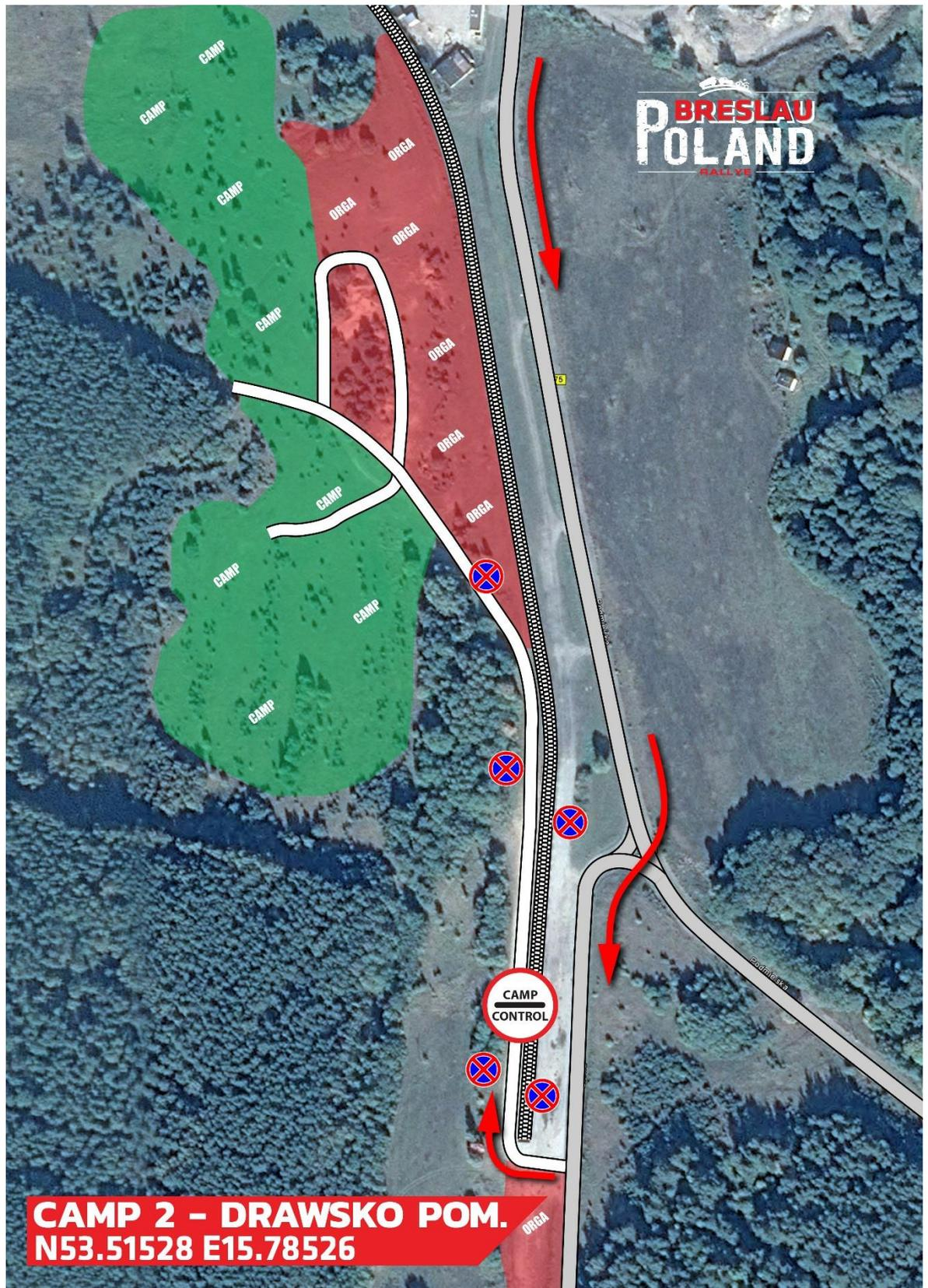

*Camp access*

The access into the first camps is with:  
**PERSONAL BARCODE AND/OR ACCESS PASS;**

Persons who don't have an entry number will have to pay a 500 € p. person deposit which will be credited in full on the registration at the Administrative Check.

Each car will receive a sticker after passing the entry check/camp control. Similar to sticker allows access to the first camp.

Example ->



After the administrative check each team will receive a set of stickers for the vehicles, which must be placed according to the stickering.

The access into the next camps is with ID card for the participants and Start numbers for the vehicles.

## ***SMS Service and ACCESS PASS:***

---

**On the E-MAIL entered in the online database you will get the Access Pass for the first camp. Print it out and bring it with you.**

On the MOBILE NUMBER entered in the online database you will get a SMS during the rally – for important information and changes.  
It is Important to have the correct mobile number with the country code in the database.

Please ensure that this field is completed not only for the rally participants but also for service crew.

**IMPORTANT:** Cash penalty for not registered persons caught by the control after closing the administrative check is 600,- EUR per person.

The rally team which service is caught without a registration and ID card receives 30 minutes penalty. If the person accompanies more vehicles, the fastest vehicle in the team will receive the penalty. In addition to the time penalty there will be a 600,- EUR cash penalty for the team concerned.

ALL PARTICIPANTS ARE OBLIGATED TO FOLLOW THE RULES IN THE CAMPS.

## Electricity

---

At the camps no electricity is available – self-sufficiency is required.

## Warnings

---



Beware of ticks, mosquitoes and snakes!  
Bring and use proper repellents during the rally.  
Inspect yourself and your clothes closely for ticks.

## Wildlife on the rally route

---



### What should drivers do if they encounter wildlife on the road?

Slow down - collision avoidance and driver response time are improved at slower speeds. Anticipate unpredictable behaviour from all wildlife. Some animals travel together so where there is one animal, there may be more. Watch for mother/offspring pairs.

### What should drivers do if a crash is inevitable?

Sometimes, there is no real choice except to strike the animal. If this is the case, look where you want to go, not at the animal. The vehicle tends to go where you look. Brake firmly and quickly, then look, and steer your vehicle to strike the animal at an angle. Let up on the brake just before you hit the animal. This causes the front end of your vehicle to rise and reduces the chances of the animal coming through your windshield.

### What should drivers do if an animal is hit, or if there is a dead animal beside the road?

This depends on road and traffic conditions, and the condition of the driver. Pull off the road. Turn on hazard lights. Stay away from wounded animals, as they can be very dangerous. You are not required to put an injured animal out of its misery or move a dead animal. Inspect your vehicle to see if it safe to continue driving. Call the Rally control immediately and follow their instructions. Reporting the exact location of collisions helps

wardens monitor injured animals and recover dead ones. Quick removal prevents other animals from being attracted to the highway.

**What do drivers need to know about wildlife behaviour in order to anticipate hazards?**

Animal behaviour is related to the "fight-or-flight response". There is a certain amount of space in which an animal feels safe; but once that boundary is violated, the animal's reaction is unpredictable. Even if an animal sees you, it may still jump in front of your vehicle. Some animals travel together, for example deer, bighorn sheep, and mother/offspring pairs. If one animal crosses the road, others may follow. If an animal has crossed the road, it may turn and cross again. Animals standing calmly at the side of the road may bolt unexpectedly.

## *Catering*

---

The Entry includes catering services: Catering starts with a breakfast on Tuesday morning 15.09.2020 and ends with late lunch/early dinner on Saturday evening 19.09.2020 in the Camp.

The daily menu consists of a breakfast, take away lunch package (given at breakfast) and dinner.

The catering doesn't include drinks, except coffee and tea at breakfast.

**IMPORTANT:** This year due to the additional hygienic measures the food will be packaged and served in take-away boxes. Please follow the [Covid-19 Rally Guidelines](#). Wear face mask, keep distance, wash and disinfect your hands more often.

## *Car wash and fuel stations*

---

Washing cars in the Camps is prohibited. Local car wash is available near Camps. Local fuel stations are available near the Camps.

## *Waste*

---

In the central areas of the Camps there are garbage containers. Garbage bags can be picked up within the working hours of the Rally HQ. Please leave the places clean!

All waste materials, packaging materials, exchanged vehicle parts; old tires, empty paint cans and oil, batteries, etc. must be taken and disposed by the participants themselves.

## *Oil/Liquids*

---

At any time of the rally the service teams are responsible to have oil binders and containers for disposal of oil/brake fluid, etc. Used oil must be collected.

**IMPORTANT:** In the Camps will be designated zones for disposal of the oil/brake fluid etc.

## *General environmental regulations*

The Organiser has been committed by the site owner to make every effort to protect the environment perfectly. The teams are asked to place a large plastic trap underneath their rally vehicle for the duration of the service work. The plans must be sufficiently thick, it may not be damaged and it needs to be media-resistant, i.e. resistant to oil, fuel, coolant and brake fluid, and battery acid.

Also, wild animals are living in the Polish forests. Be careful and protect them.

## *Refuelling*

Refuelling is authorized at fuel commercial stations servicing the towns crossed by the rally route or along the national route and it must be paid in euro or local currency.

The petrol stations where competitors may refuel are indicated in the road book. When no petrol stations are available close to the Camps, fuel (petrol and diesel) for competitors and registered service vehicles only, will be available at the overnight Camps from the refuelling tank truck provided by the Organization.

Refuelling among competitors is also authorized.

Carrying fuel in the vehicle is strictly forbidden.

It is foreseen by the Organizer for refuelling areas to be placed during long special stages. Therefore, the participants should bring metal jerry cans.



### **FUEL AUTONOMY:**

- Enduro, ATV around 130 km.
- SSV, Cars & Trucks around 200 km.

Each competitor is responsible of the calculation of his autonomy. He cannot in any case make up against the Organization if his vehicle doesn't reach the coverage of the minimum distance of 130 km respectively 200 km, whichever is the nature of the terrain. For safety reasons, an additional autonomy of 10% is recommended.

For safety reasons, when refuelling at camps, crews must ensure to be placed far from inflammable material such as dry grass or dry tree branches, and to be at safety distance from other vehicles. The refuelling responsibility concerns also the crew, engines must be off and the people must remain outside the vehicle during refuelling.

### ***Advertising and identification. Sticker plan.***

Access to the rally (start and finish of the Legs, service points, camps, etc.) is exclusively reserved to all those wearing the identifying card of RBI Sport (competitors, service, organisation members, media delegates, visitors, VIP) and to all vehicles officially registered (competitors, service, press, ORGA) supplied with the official stickers of the event.

#### **ADVERTISING AND STICKER PLAN**

The stickers' space reserved for the Organisers official advertising and start numbers are described in the official Sticker Plan that is under no exception compulsory for all the participants in the rally (crews, service and press).

#### **COLLECTIVE ADVERTISING PLATES:**

- Motorcycles and ATV - 2 plates measuring 12x8cm plus 2 plates measuring 12x12cm
- SSV – 2 plates measuring 30x28cm
- Cars – 2 plates measuring 42x40cm
- Trucks – 2 plates measuring 50x47cm

### **[FOLLOW THE LINK TO VIEW THE STICKER PLAN >>>](#)**

The stickers will be distributed to competitors at the dedicated place and shall be affixed according to the defined in the sticker plan layout by the participants.

Participants are obliged to attach the start numbers and the stickers with the advertisements of the rally sponsors on their vehicles according to the given plan. The stickers must be visible for the duration of the rally.

This means that at least the areas of the vehicles with the official event stickers have to be cleaned every day, so that the stickers remain visible.

Noncompliance to the sticker plan will result in a scrutineering refusal. Any deliberate removal of the organisers/sponsors sticker will result in a possible disqualification or/and cash penalty equivalent to 20% of the entry fee (per person). The scrutineer or any rally official present has the final word in this matter.

At any time during the rally, the absence or faulty positioning of the stickers may incur, on certification, a cash penalty equivalent to 10% of the entry fees (per person). The absence

or faulty positioning of the stickers same time may result in a cash penalty equivalent to 20% of the entry fee (per person).

Competitors are allowed to affix any kind of advertising to their vehicles, provided that:

- it is not likely to give offense;
- it does not encroach upon the spaces defined in the sticker plan;
- it does not interfere with the crew's vision through the windows;
- it does not express either a religious and/or political opinion.

No political, religious or abusive advertising is permitted. The advertising of tobacco (or related products), alcohol and/or pornography is forbidden on cars, competition/service equipment and on the team members' outfits.

## *Identification*

---

Each participant at the events of RBI Sport (competitors, service, organisation members, press delegates, VIP, visitors) will get an identifying card (ID card), included in the entry fee.

The ID card worn around the neck, mechanics and assistance personnel, visitors, VIP, are considered the only authorization to access the rally official location, service areas, press or visitor's points and the camps.

The ID card will be systematically checked by the Organisation at meals, at service points or service areas, at the camps, etc. Participants must show the ID card at any moment upon request.

Any infringement found by an Organisation official, will imply a penalty of 300,- EUR. In case of damage of the ID card, the participant must refer to the Rally Administration.

## Rally signs

### Rally Control Signs

#### Time control



Color of control Area Entry - YELLOW  
Color of point - RED

#### SS Start



Color - RED

#### Flying Finish line



Color of control Area Entry - YELLOW  
Color of point - RED

#### Stop Control



Color - RED

#### End of Control Area



Color - BEIGE

#### Control point with stamp



Color of control Area Entry - YELLOW  
Color of point - RED

#### Begin of Refuel Zone



Color - BLUE

#### End of Refuel Zone



Color - BLUE

#### Control point no stop

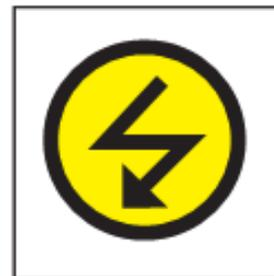

Color of control Area Entry - YELLOW  
Color of point - RED / BLUE / BLACK

## Rally Control Zones

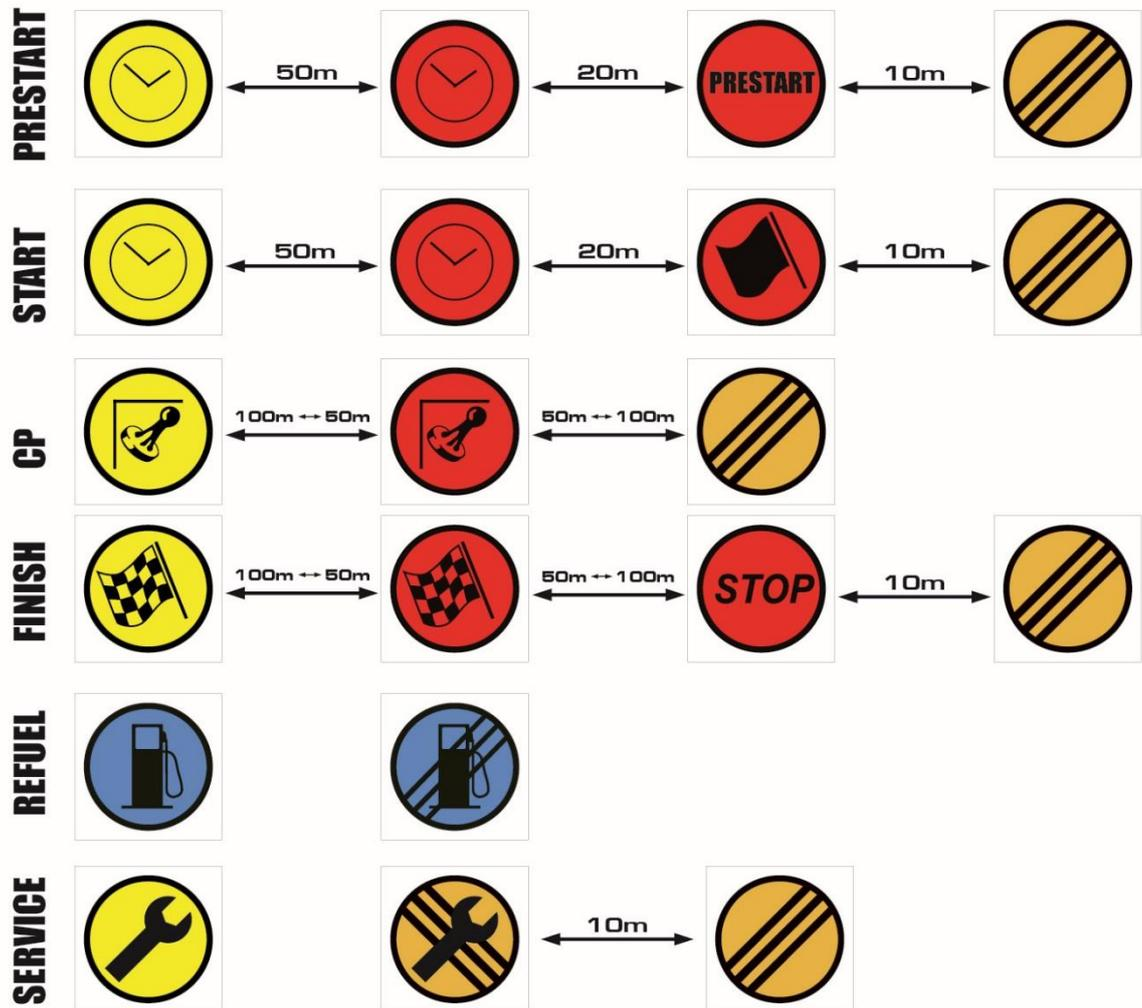

## Manual start handling

In case of malfunction of the regular starting-system, manually start will be used. The starting procedure will be both by speech (in English) and by signs. The starter will stand to the right in front of the car.

Manual starting procedure:

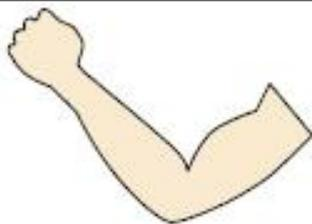
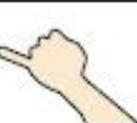
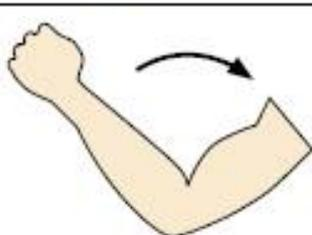
TIME TO START	ORAL	SIGN
30 SEC	30	
15 SEC	15	
10 SEC	10	
5 SEC	5	
4 SEC	4	
3 SEC	3	
2 SEC	2	
1 SEC	1	
0	GO	

## Instructions for safety

---



### MAIN SAFETY RULES:

**Attention:** The rally sport is attractive, but it could be dangerous! As a spectator of a rally competition, you must compulsory respect the main rules for security and for your personal safety! The red zones on the diagram are absolutely prohibited for spectators!

- ⚠ Always be on time on the preliminary selected points for spectators!
- ⚠ Never come closer to the dangerous zones!
- ⚠ Always stay behind the fences and the restriction bands set by the Organizer or stay behind something solid!
- ⚠ Never stay on places where it will be impossible to leave in a case of a dangerous situation!
- ⚠ Do not park your cars in a way to block the racing track of competitors!
- ⚠ Never stay on spots that are under level of the racing track!
- ⚠ Do not cross the racing track on any occasion!
- ⚠ Always think not only for your personal safety, but also for the safety of the competitors! Do not make their life more difficult!
- ⚠ If you are with children, do not leave them without control!
- ⚠ Do not leave your spot before the passage of the organizer's car which announces the end of the special stage!
- ⚠ Expect the unexpected!
- ⚠ Keep the nature clean!

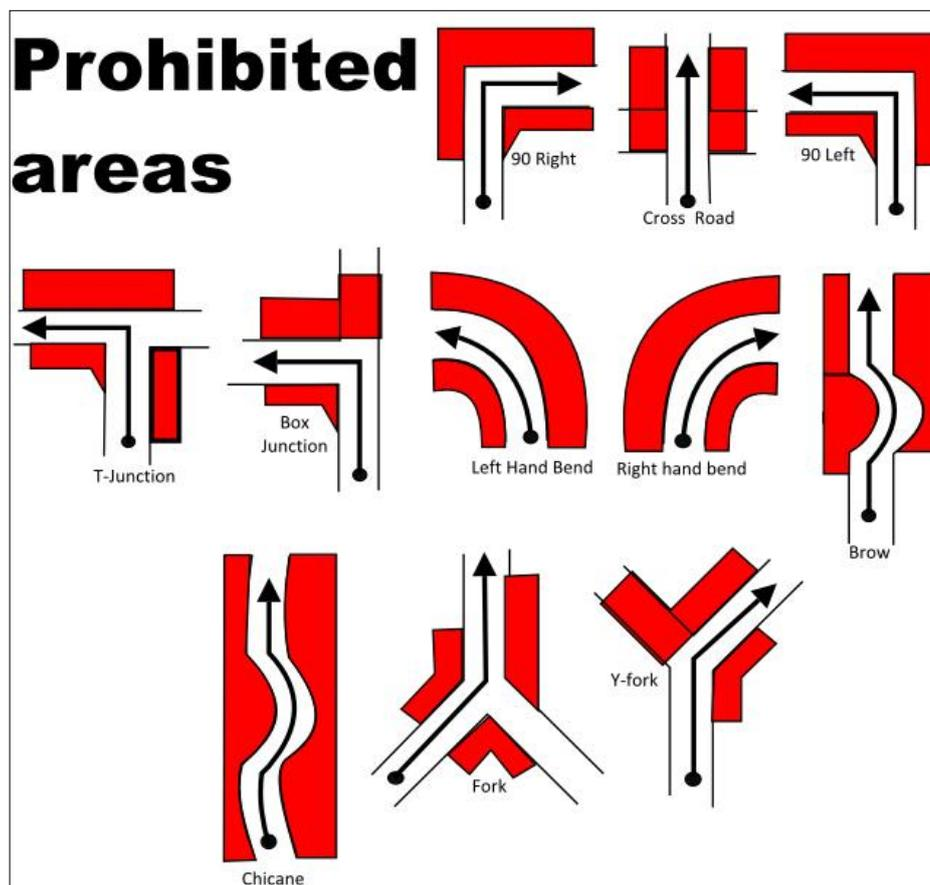

## Useful Information

### GEOGRAPHY

- Size: 312,679 km<sup>2</sup>
- Capital: Warsaw
- Borders: Germany to the west; the Czech Republic and Slovakia to the south; Ukraine, Belarus to the east; and the Baltic Sea and Kaliningrad Oblast (a Russian exclave) and Lithuania to the north
- Time zone: CET (UTC+1)
- Currency: Złoty (PLN)
- Calling code: +48
- Official language: Polish (English and German widely spoken)

### HIGHWAY TOLLS

Detailed information about the highways in Poland and the highway tolls can be found here:

<https://www.viatoll.pl/en/home>

## EMERGENCY PHONES

The general emergency number for mobile phones:



### From fixed phones:

**999:** Ambulance

**998:** Fire Brigade

**997:** Police

**981:** Road Assistance

**986:** Municipal Police

*Using mobile phones: remember to dial the local code before the number, for example: 22 - 997 to call the police in Warsaw. Emergency calls from phone boxes are free of charge. If you do not know the local code, dial the general emergency number for mobile phones: 112. The operator will request the appropriate emergency unit.*

## HOSPITALS AND EMERGENCY SERVICES

Drawskie Centrum Specjalistyczne  
Dyrektor lek.med. A. Bielicki  
ul. B. Chrobrego 4  
78-500 Drawsko Pomorskie  
Tel: +48 94 363 03 41

Szpital w Szczecinku Szczecinku  
Kościuszki 38  
78-400 Szczecinek  
Phone number +48 94 372 67 11

Peozet  
28 Lutego 3  
78-400 Szczecinek  
Phone number +48 94 372 43 83

Pomorski Ośrodek Diagnostyki Medycznej  
Podimed  
Spółdzielcza 8  
78-400 Szczecinek  
Phone number +48 94 372 94 00

Szpital Wojewódzki w Poznaniu  
ul.Juraszów 7/19  
60-479 Poznań  
Tel: +48 61 8212-200  
szpital@lutycka.pl

### CITY CODES:

International code of Poland: +48

Currency exchange rates as per  
11.08.2020 according to NBP:

City codes:

Drawsko Pomorskie: + 48 94 XXXXXX

Szczecinek: + 48 94 XXXXXX

Poznan:+48 61 XXX

1 EUR = 4,4123 PLN

1 GBP = 4,9028 PLN

1 USD = 3,7558 PLN